

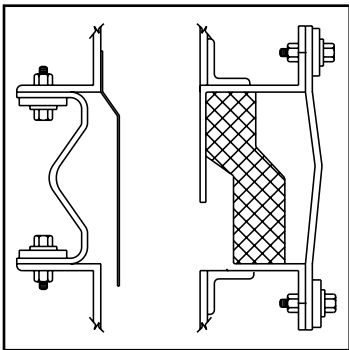

aerospace
 climate control
 electromechanical
 filtration
 fluid & gas handling
 hydraulics
 pneumatics
 process control
 sealing & shielding



Non-Metallic Expansion Joints

For Power Generation, Industrial and Institutional Applications



ENGINEERING YOUR SUCCESS.

Parker is the Global Leader in Innovation and Design of Advanced Products and Sealing Systems for Power Generation.



Contents:

History	3
Power Generation Applications	
Coal Fired.....	4
Combustion Gas Turbine.....	5
Combined Cycle.....	5
Commitment to Quality	6
Design Expertise	7
Material Selection Guide.....	8
Typical Frame and Baffle Configurations	9
Movement Table.....	10
Design Request Form	11

YOUR CHALLENGES:

Cost. Efficiency. Availability. Utilization. Downtime.

OUR SOLUTIONS:

Available. Reliable. Consistent. Efficient. Robust.

You demand products and system-ready solutions that deliver flexibility, performance and reliability – from a global technology leader you trust.

Parker is your go-to collaborative design partner and technology expert for sealing and expansion joint solutions. We are the only source for the trusted RM[®] Dynex and JM Clipper[®] non-metallic expansion joint products and have a global expansion joint install base of over 75,000.

Our design engineers have the expertise to tackle the most challenging and unique customer problems and Parker's wide range of engineered materials and construction choices ensures our ability to find solutions for the most difficult projects.

Doing business with Parker gives our customers the advantage of cutting-edge technology for a multitude of power plant and industrial processes.

Our specialized Energy Sales Team works intimately with plant engineers to develop and implement system-wide solutions from a variety of Parker products including filtration, hose and piping, hydraulics, instrumentation and controls, as well as sealing systems and expansion joints.

History

If your knowledge of expansion joints is limited to brand names, here's a little history to connect the dots to Parker.

1960's: Johns-Manville and Raybestos Manhattan, both companies that specialized in producing asbestos based products, begin manufacturing non-metallic expansion joints. Johns-Manville focused on gas turbine applications. Raybestos Manhattan focused on coal-fired and environmental applications.

1989: JM Clipper split from Johns-Manville, focusing on rotary sealing products and expansion joints.

1990's: Dynex founded to focus on general industrial applications.

1997: Raybestos Manhattan acquired Dynex to form RM-Dynex.

2001: JM Clipper acquired RM[®] Dynex to become the largest and most diverse expansion joint company in North America.

2004: Parker Hannifin acquired JM Clipper, strengthening its sealing technologies and expanding its materials portfolio with expansion joint constructions.

2004 - Parker Hannifin acquires JM Clipper

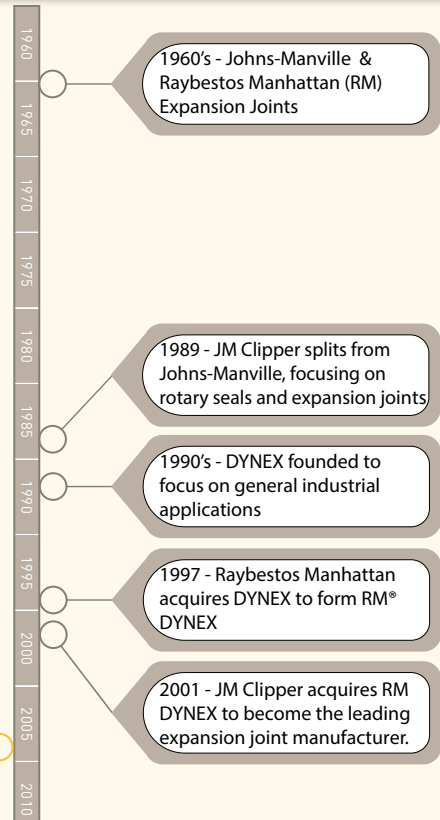

Expansive Range of Solutions

Parker's expansion joints manage air and gas handling systems for the Power Generation, Industrial & Institutional industries, including:

- Simple Cycle, Combined Cycle, Cogen, and Coal Fired power plants
- Industrial operations such as steel mills, paper mills, and cement plants
- Institutional sites such as hospitals, schools and university campuses

Unlimited combinations of our material portfolio, frame, baffle, insulation and attachment styles give us the flexibility to meet the thermal, chemical and environmental demands of diverse systems, equipment and processes, including:

- | | | |
|---|--|---|
| <ul style="list-style-type: none"> □ Air and steam transport lines □ Air ducts □ Air heaters □ Ash transport systems □ Boilers □ Boiler inlets & boiler outlets □ Bypass channels □ Chemical process lines □ Chemical reactors □ Chimney stacks □ Coal feed transport systems □ Coal mills □ Compressor / pumping stations □ Condensers | <ul style="list-style-type: none"> □ District heating & cooling □ Economizers □ Exhaust systems □ Flue gas ducts □ Filtration / precipitators □ Forced draft (FD) fans □ Flue gas desulfurization (FGD) □ Flue gas ducts □ Feed processing lines □ Gas and steam turbines □ Gas turbine inlets □ Heat exchangers □ HRSGs (heat recovery steam generators) | <ul style="list-style-type: none"> □ Induced draft (ID) fan □ Inlets □ Lubrication systems □ Penetration seals □ Process lines □ Scrubbers / Absorbers □ Selective catalytic reduction (SCR) □ Stacks □ Steam transport lines □ Steam turbines □ Storage tanks □ Water cooling systems □ Wet Scrubbers |
|---|--|---|

POWER SOURCE: COAL FIRED



Look to Parker for:

- | | |
|---|---|
| <ul style="list-style-type: none"> • Air ducts • Air heaters • Boilers • Bypass ducts • Chimney stacks • Coal mills • Economizers • Exhaust • Flue gas desulfurization (FGD) | <ul style="list-style-type: none"> • Flue gas ducts • Forced draft (FD) fan • Induced draft (ID) fan • Inlets • Precipitators / Baghouse • Selective catalytic reduction (SCR) • Wet scrubbers |
|---|---|

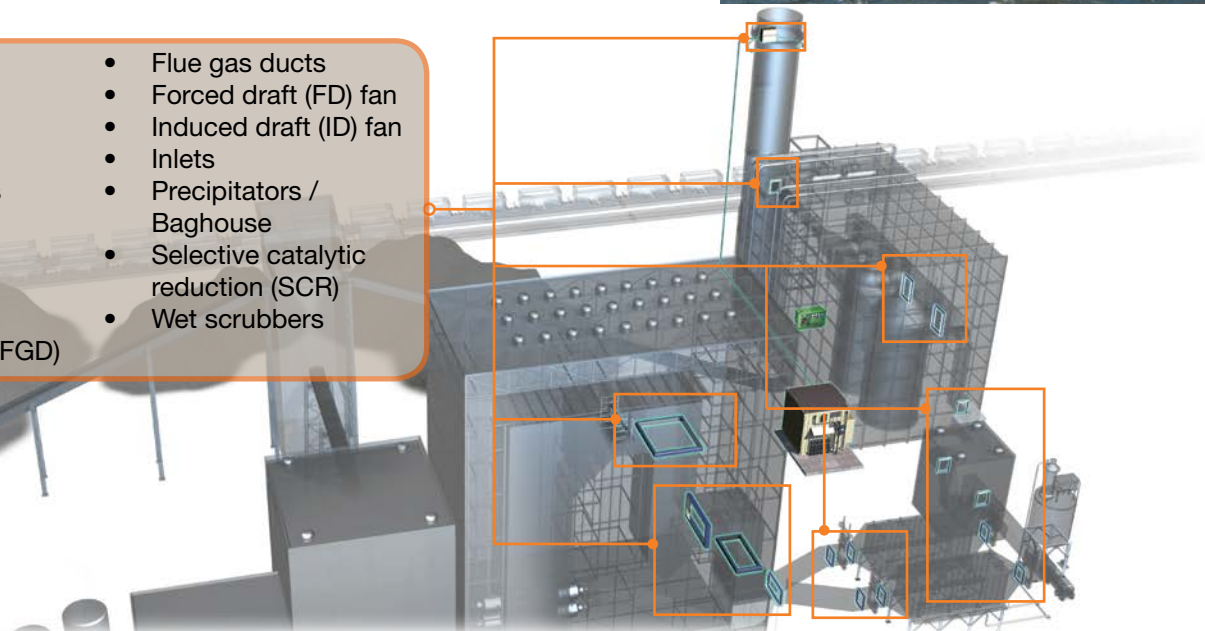

POWER SOURCE: COMBUSTION GAS TURBINE



Look to Parker for:

- Inlets
- Auxiliary inlets
- Plenum
- Bypass
- Compressors
- Exhaust
- Auxiliary exhaust

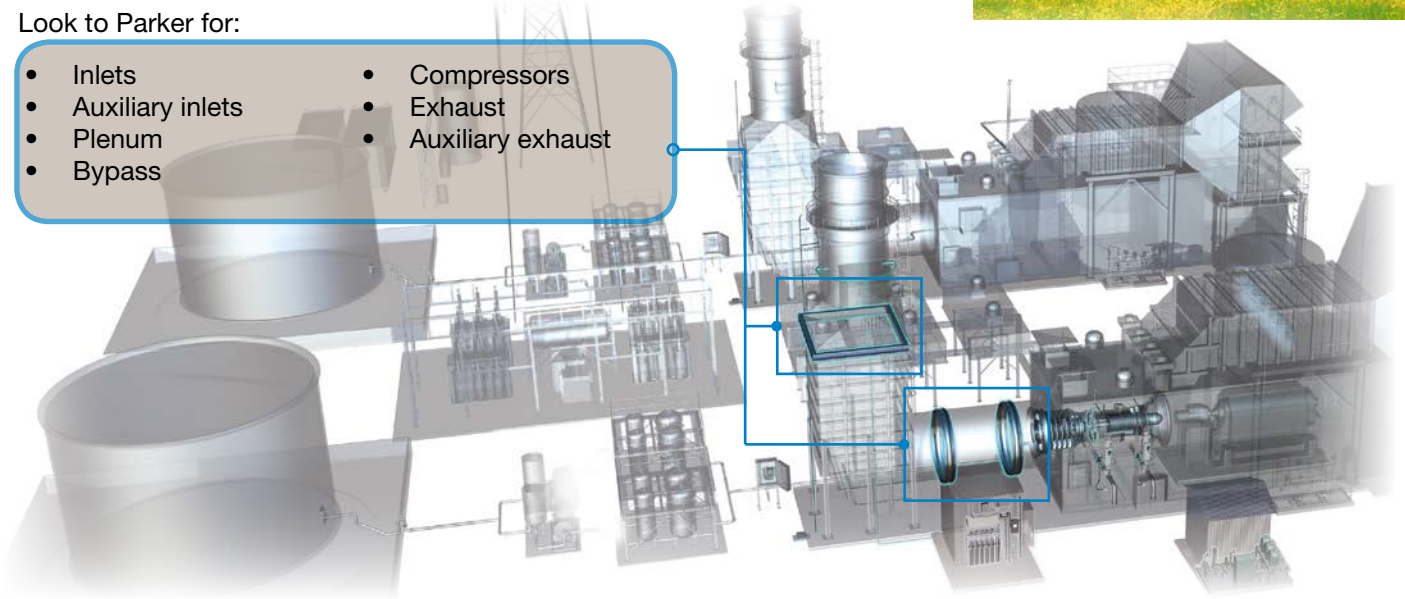

POWER SOURCE: COMBINED CYCLE



Look to Parker for:

- Inlets
- Auxiliary inlets
- Plenum
- Bypass
- Compressors
- Exhaust
- Auxiliary exhaust

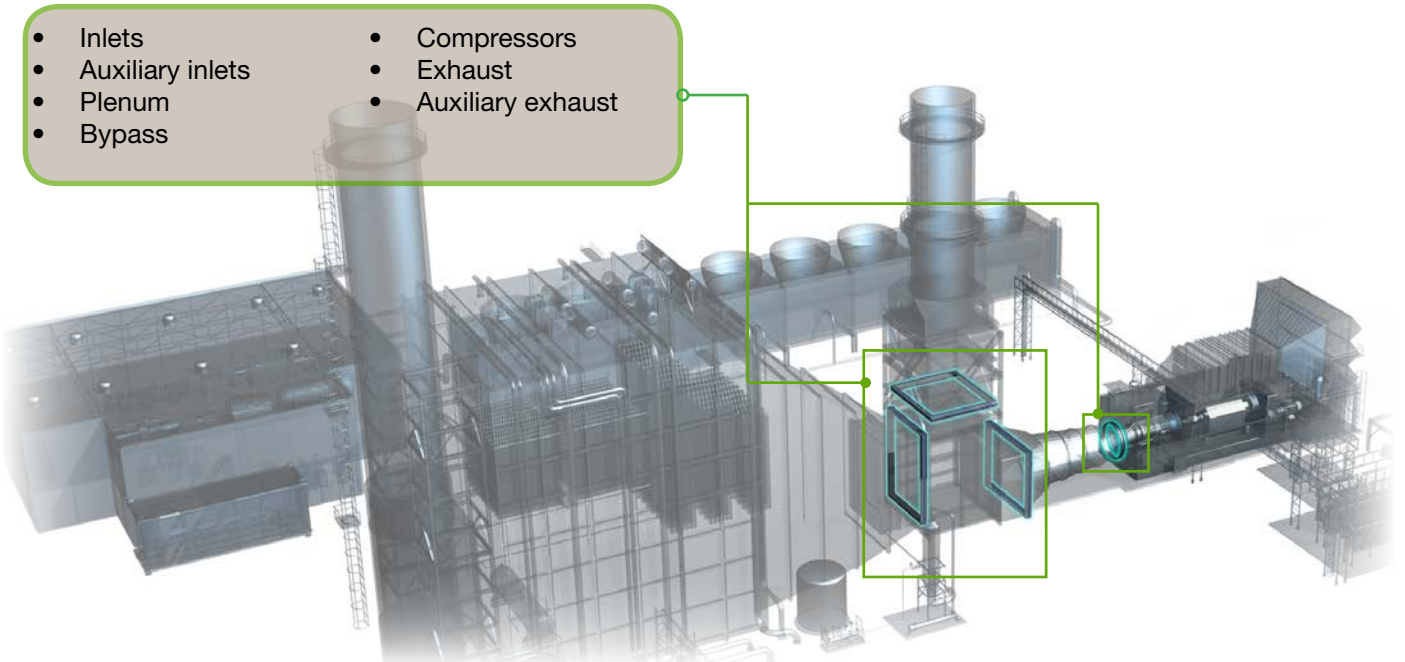

Commitment to Quality

Quality Assurance

To ensure product integrity, our expansion joint manufacturing operations are certified to ISO 9001 standards. Parker is committed to consistently delivering excellence in quality and service through continuous improvement of our people, products and systems.



Expansion joints are manufactured at Parker's site in Nacogdoches, Texas.



ISO 9001 Certified

What our customers say

Our commitment to high quality and reliable service is supported by our investment in technologically advanced test and inspection methods. We're constantly striving to improve customer satisfaction and product quality through the implementation of:

- Six Sigma methodology
- Lean manufacturing
- Advanced Product Quality Planning (APQP)

Association Membership

Parker participates in and conforms to standards developed by the following industry associations:

- Fluid Sealing Association (F.S.A.)
- ASTM
- PVRC
- ASME

"In my role as maintenance engineering manager for a large multi-national company, I've been specifying Parker Hannifin fabric expansion joints for many of our boiler duct applications for the past 40 years.



Over these years we have found Parker Hannifin's fabric expansion joints to be manufactured with good quality that results in years of reliable service and operation for our plants. Parker is continually responsive to our needs, and has always demonstrated willingness to stand behind their products.

We can rely on their delivery schedules, and know that they are always willing to "step up" in an urgent situation. We expect to continue to use Parker Hannifin fabric expansion joints in our plants for many years to come."

Design Expertise

Custom Designs

Expansion joints are custom designed and made-to-order to manage the thermal expansion, noise reduction, vibration, wind & seismic loads, movement absorption and system stress relief conditions unique to each customer's site.

Wide Range of Construction Types

Our portfolio of fabric expansion joint styles spans a broad range of configurations and multi-layer construction types which include:

- Elastomer belts capable of withstanding temperatures up to 2,200° F (1204° C)
- U-type corner, belted rectangular corner, round and odd/custom shape joints
- Over 100 materials available in 1,000+ design combinations
- Frame styles with and without internal baffles and flow liners
- Insulation pillows (normally required for operating temperatures over 750° F)
- Hot-to-hot, hot-to-cold, and cold-to-cold frame-to-duct equipment configurations
- Horizontal, vertical and angled flow direction

Advanced Materials

Parker is dedicated to and focused on innovative development of new products and services to meet the growing needs of its customers. Our expansion joint constructions include non-metallic belts made from EPDM, FKM, CR, Silicone, and PTFE materials. High temperature resistant fabric covers are used to insulate the sealing materials.

Frames, baffles and backup bars are constructed of carbon steel or the higher nickel steels available for today's demanding environments.



Temperature resistant insulation pillow

Construction

The photo below illustrates a typical belt geometry expansion joint for flue duct gas management. Its construction components include:

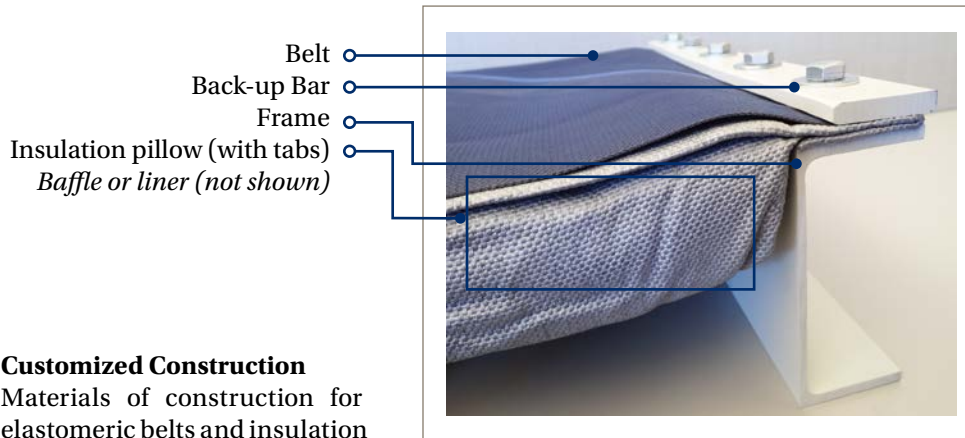

Customized Construction

Materials of construction for elastomeric belts and insulation pillows, if required, are selected based upon performance requirements and the specific operating conditions of the customer's application including:

- Temperature
- Movement
- Media (wet and/or dry)
- Chemical compatibility of gas and particulate
- Environmental exposure
- Level of contamination or particulate volume (fly ash)
- External environment
- Safety and/or any regulatory requirements

Configuration of metal frames, baffles and flow liners is based upon:

- Method of attachment
- Direction of flow
- Belt style

Illustrative cross-sections

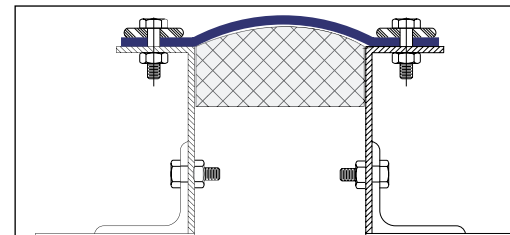

Figure 1. Frame with belt and insulation pillow

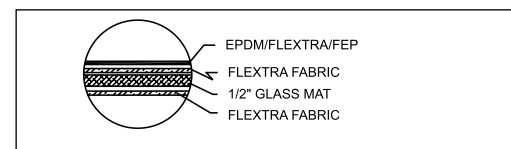

Figure 2. Multi-layer belt

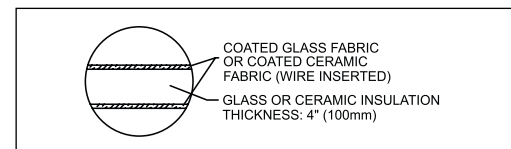

Figure 3. Multi-layer insulation pillow

Material Selection Guide

Parker RM Dynex fabric expansion joint belt materials are available in EPDM, FKM, Chloroprene (CR), Silicone (VMQ), and PTFE. Whether utilized as a shell, barrier or buffer layer, elastomers may be reinforced and bonded with composite cloths including fiberglass, ceramics, aramid fiber, and stainless steel to suit service conditions and performance requirements.

Common Materials

Figure 4 and Table 1 show temperature capability ranges and chemical and exposure compatibility of several common belt materials. Parker offers hundreds of possible combinations to meet specific conditions.

Specification Assistance

Call our application engineers for assistance in specifying the optimal material and frame configurations to meet your site needs.

Figure 4. Temperature Capability Range of Common Belt Materials

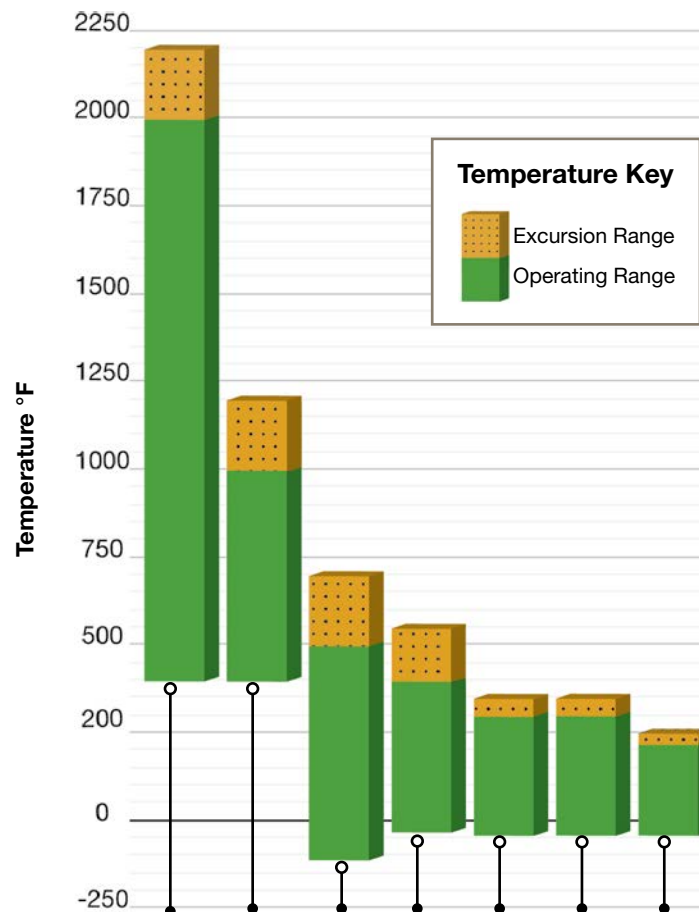

Table 1. Chemical and Exposure Compatibility of Common Belt Materials

	Material Type						
	Composite (Ceramic/PTFE)	Composite (Fiberglass/PTFE)	PTFE	FKM	EPDM	Chlorobutyl	Chloroprene
Sunlight	Green	Green	Green	Green	Green	Green	Yellow
Oxidation	Green	Green	Green	Green	Green	Green	Yellow
Ozone (O3)	Green	Green	Green	Green	Green	Green	Yellow
Abrasion	Green	Green	Red	Green	Green	Green	Green
Sodium Hydroxide (NaOH) (>20%)	Green	Green	Green	Green	Green	Green	Green
Sodium Hydroxide (NaOH) (<20%)	Green	Green	Green	Green	Green	Green	Green
Anhydrous Ammonia	Green	Green	Green	Red	Green	Green	Green
Hydrochloric Acid (HCl) (>20%)	Red	Green	Green	Yellow	Red	Red	Red
Hydrochloric Acid (HCl) (<20%)	Red	Green	Green	Green	Yellow	Yellow	Red
Sulfuric Acid (H2SO4) (>50%)	Green	Green	Green	Green	Red	Red	Red
Sulfuric Acid (H2SO4) (<50%)	Green	Green	Green	Green	Green	Green	Red

Typical Frame Configurations

Precision Fit

Metal frames, baffles and flow liners are precision matched to fit the design envelope of the customer's application. Baffles and liners are specified to manage flow and lessen the accumulation and trapping of particulate.

Parker's rectangular corner design splits the clamping bar at the point of tangency, allowing for better sealing. In addition, our robust bolt distance spacing ensures consistent clamping force.

Figure 5. Rectangular Corners

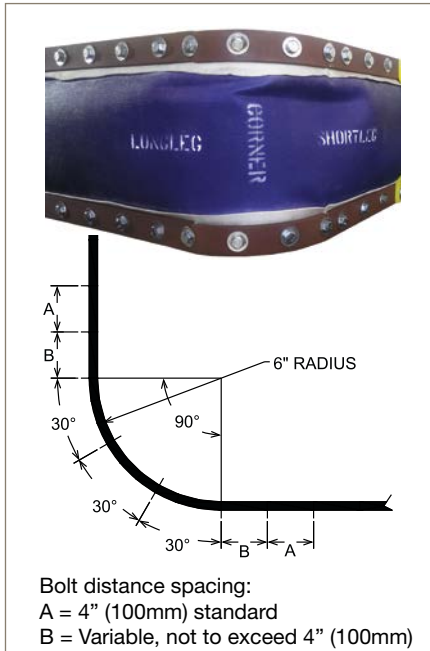

Figure 6. Metal Attachment Frames

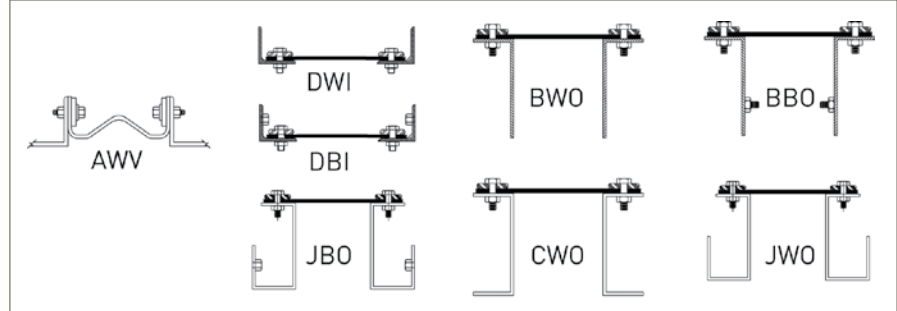

Figure 7. Metal Attachment Frames With Baffles (Liners)

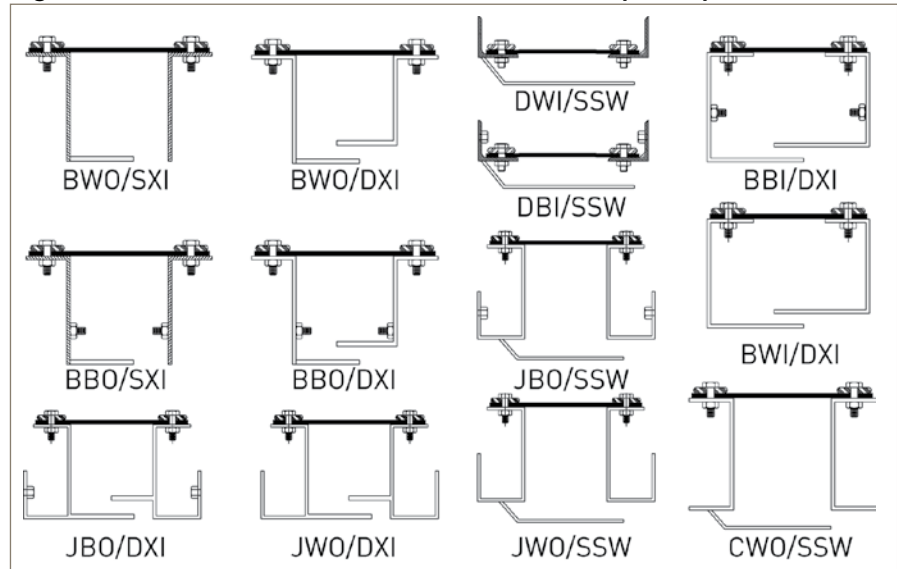

Figure 8. Metal Baffles (Liners)

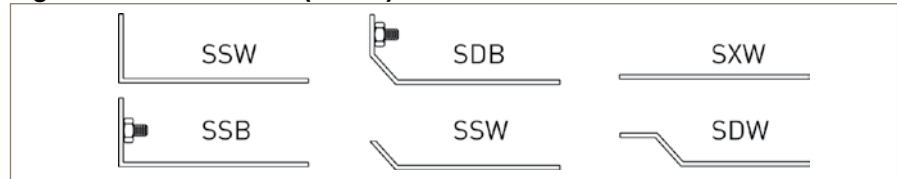
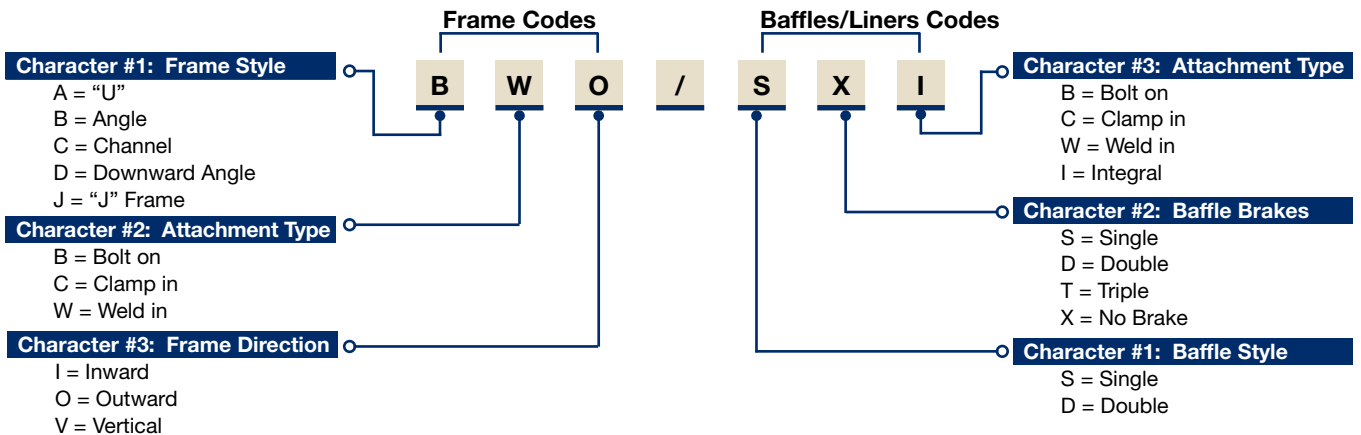

Table 2. Metal Attachment Frame & Baffle Identification Codes



Movement Table

The table below may be used in two ways:

- 1 - Given a specified breach opening, estimate the amount of motion which can be absorbed.
- 2 - Given a set of motions, determine the breach opening required to accommodate the same.

Table 3. Movement Table – Inch (mm)

Breach Opening	6"	8"	10"	12"	14"	16"	18"	20"	22"	24"
	(150)	(200)	(250)	(300)	(350)	(400)	(450)	(500)	(550)	(600)
Manufactured F/F	6.5"	8.5"	11"	13"	15"	17"	19"	21"	23"	25"
	(163)	(215)	(275)	(325)	(375)	(452)	(475)	(525)	(575)	(625)
Axial Compression (Operating)	1.5"	2.25"	3.25"	4"	4.75"	5.625"	6.25"	7"	7.5"	8.5"
	(40)	(60)	(80)	(100)	(120)	(140)	(155)	(175)	(190)	(210)
(Excursion)	3.25"	4.375"	5.5"	6.5"	7.5"	8.5"	9.5"	10.5"	11.5"	12.5"
	(80)	(110)	(140)	(165)	(190)	(215)	(240)	(265)	(290)	(315)
Axial Extension (Operating)	0.5"	0.5"	1"	1"	1"	1"	1"	1"	1"	1"
	(15)	(15)	(25)	(25)	(25)	(25)	(25)	(25)	(25)	(25)
Resultant Lateral (Operating)	1.5"	2.25"	3.25"	4"	4.75"	5.625"	6.25"	7"	7.5"	8.5"
	(40)	(60)	(80)	(100)	(120)	(140)	(155)	(175)	(190)	(210)
(Excursion)	2.375"	3.375"	4.375"	5.375"	6.25"	7"	7.5"	8.5"	9.5"	10.6"
	(60)	(85)	(110)	(135)	(155)	(175)	(190)	(215)	(240)	(265)

Movement Types

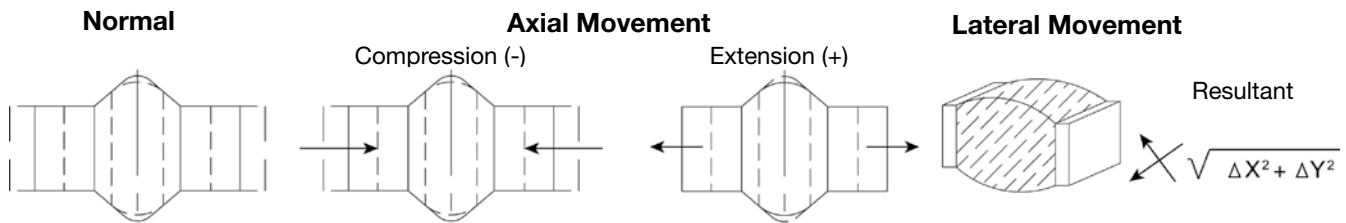

Breach Opening & Flow References



Design Action Request Form

Please fill out the required information and return the completed form to Parker: Email: eps-ccare@parker.com
 Link to downloadable form may be found at: www.parker.com/eps/powergen
 If you need assistance filling out the form, please call: 800-233-3900 and ask for Application Engineering.

Customer's Name	Date:	Page of
Mailing Address	Project Name:	Delivery Required Date:
City, State, Zip Code	Specification #:	Inquiry #:
Name of person submitting data	Phone #:	Email:
Quantity Per Item		
<input type="checkbox"/> New or <input type="checkbox"/> Replacement (check one) Please forward all drawings of ducting, expansion joints. If replacement please furnish drawings of existing joint.		
SERVICE		
Type of plant/service: (Precipitator, Scrubber, etc.)		
Type of fuel and percent sulfur:		
Peak load or base load:		
Number of startups and shutdowns per year:		
Location of expansion joint (I.D., Fan outlet, Stack, etc.):		
DIMENSIONS		
Duct Size - Inside Dimensions or Diameter (Inches):		
Breech Opening (Inches):		
FLOW / MEDIUM		
Flowing Medium: (air, flue gas, etc.)		
Dust Load: (PSF)		Flow Velocity: (FPS)
Flow Direction: <input type="checkbox"/> UP <input type="checkbox"/> DOWN <input type="checkbox"/> HORIZONTAL <input type="checkbox"/> ANGULAR UP <input type="checkbox"/> ANGULAR DOWN (check one)		
PRESSURE		
Design Pressure: (Inches Hg)	Maximum:	Normal:
TEMPERATURE		
Gas Temperature (°F):	Normal:	Continuous:
Maximum Temperature (°F): (Upset)	Duration Per Event:	Cumulative Duration:
Ambient Temperature (°F):	Minimum:	Maximum:
MOVEMENTS OF EXPANSION JOINT		
Axial Compression: (Inches)		Axial Extension: (Inches)
Lateral Deflection: (Inches)	One Direction:	Second Direction:
Angulation: (Degrees)	Torsion: (Degrees)	
DUCT		
Duct Material:		Duct Thickness:
Internal Liner/ Baffle Required? <input type="checkbox"/> Yes <input type="checkbox"/> No		
Comments/Notes (If any):		



Parker Hannifin Corporation
Engineered Polymer Systems Division
phone 800 233 3900
www.parker.com/eps